

WITH VERTICAL CURB

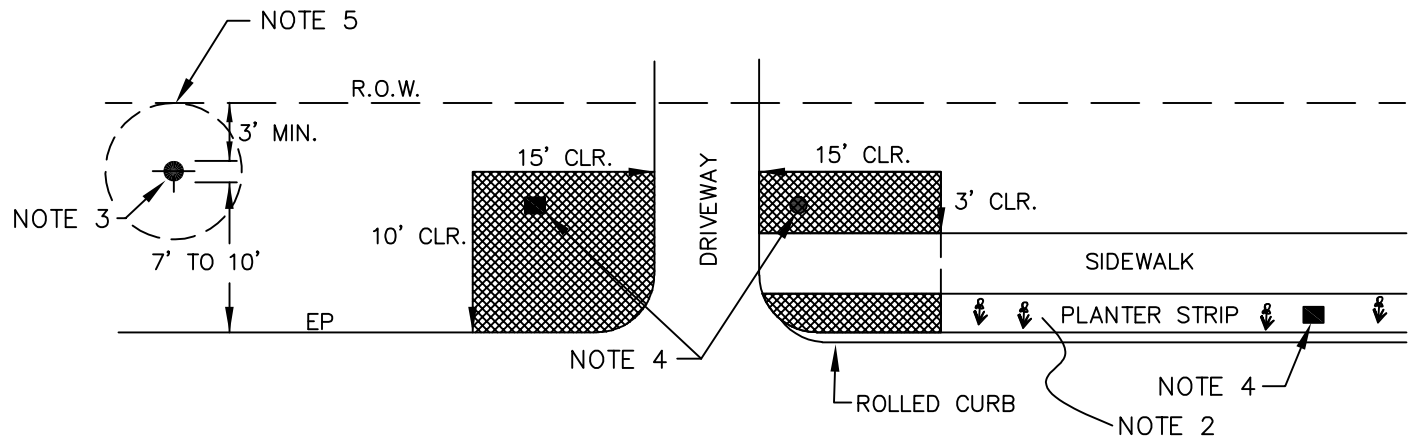

WITHOUT VERTICAL CURB

 CLEAR ZONE, NO ABOVE GROUND APPURTENANCES.

NOTES:

1. MAINTAIN 3FT. CLR FROM FACE OF CURB AND 1FT CLR FROM EDGE OF SIDEWALK. WHEN PLANter STRIP WIDTH IS 6FT OR GREATER, CENTER HYDRANT IN STRIP.
2. NO ABOVE GROUND APPURTENANCES IN THE PLANter STRIP BEHIND ROLLED CURBS.
3. HYDRANTS TO BE LOCATED 3FT. FROM THE EDGE OF RIGHT OF WAY.
4. BELOW GROUND FACILITIES IN CLEARANCE AREAS, SIDEWALKS AND PLANter STRIPS MUST BE RATED FOR TRAFFIC LOADING.
5. FIRE FIGHTER CLEAR ZONE NO ABOVE-GROUND OBSTRUCTIONS OR LANDSCAPING. EASEMENTS WILL BE REQUIRED FOR THE FIREFIGHTER CLEAR ZONE OUTSIDE OF THE R.O.W.



City of Bellevue

WATER UTILITY

TITLE
ROADWAY CLEARANCES
FOR ABOVE GROUND APPURTENANCES